

➤ Venting chimney BKA 1



The figure shown here may contain special accessories

Venting chimney DN 150 (154 mm outside dia.), with insect-proof stainless steel screen, mesh 1x1 mm, free sectional area 37%, with attached hood, completely made of 1.4307 (AISI 304 L) stainless steel.

I. Vertical installation

Length L = _____ mm

II. Wall installation

Flange for bolted fixing to the outer tank wall, drain trap DN 20 for condensate with stainless steel screen, lateral wall distance to pipe axis: 227 mm. Vertical pipe length

L = _____ mm

Completely shielded arc welded, acid-treated in a pickling bath and passivated.

Options I for vertical installation:

- Adjustable wall flange
- Welded-on wall flange
- Welded-on dowel flange
- Rubber seal and fixing material for the dowel flange
- Pipe saddle DN 150, wall distance to pipe axis: 227 mm \pm 30 mm
- PVC connection possible (only for manhole interior)

Options II for lateral installation:

- Guard grille for dowelling to the inner tank wall, mesh 10 x 10 mm, free cross section, 55%
- Rubber seal and fixing material for the dowel flange
- Pipe saddle DN 150, wall distance to pipe axis: 227 mm \pm 30 mm

Options for both installation variants:

- Replaceable pollen filter
- Tubular biofilter within the ventilating chimney for odour elimination
- 1.4404 (AISI 316 L) stainless steel
- Other pipe diameters

I. Senkrechter Einbau
 (Darstellung mit Mauerflansch)
 I. vertical installation
 (version with wall flange)

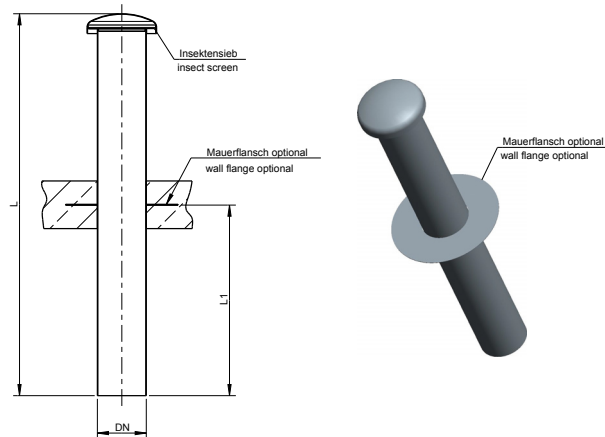

II. Seitlicher Einbau
 II. wall installation

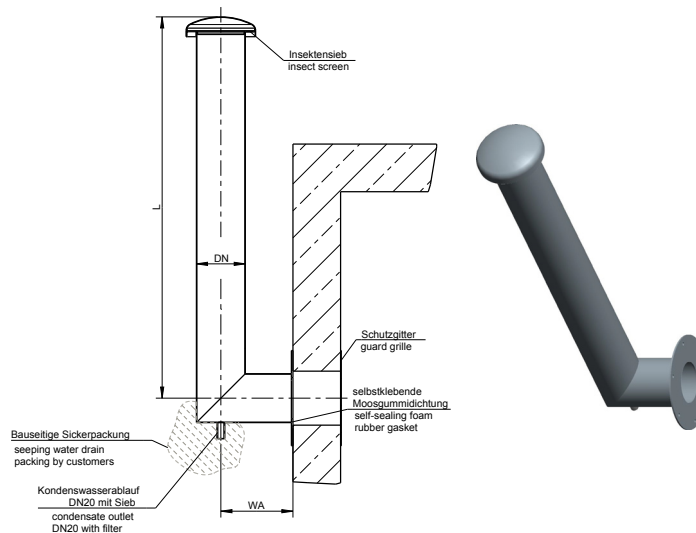

Order no.	Length, only for vertical type (I.)
BKA 1000	1000
BKA 1500	1500
BKA 2000	2000
BKA 2500	2500
BKA 3000	3000
BKA 3500	3500

HUBER SE

Industriepark Erasbach A1 · D-92334 Berching
 Phone: + 49 - 84 62 - 201 - 0 · Fax: + 49 - 84 62 - 201 - 810
 info@huber.de · Internet: www.huber.de

Subject to technical modification
 Drawing no. 50945691, 5.2022

Venting chimney BKA 1