

Schnitt/section: A-A

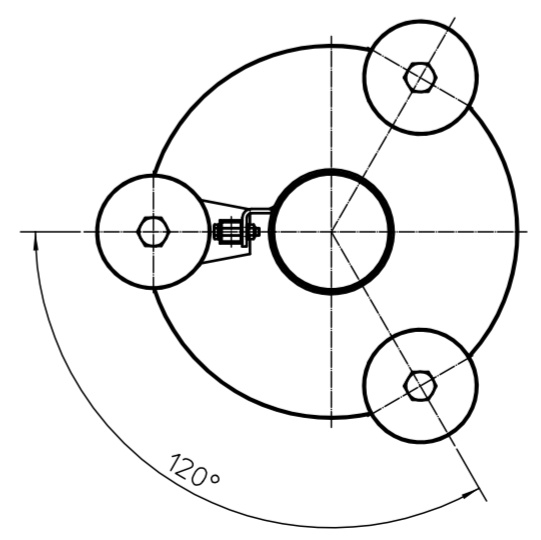

Pos. Menge	Bezeichnung		Merkstoff/Lieferant		Bemerkung	
Item Quantity	Specification		Material/Supplier		Annotations	
Diese Zeichnung ist geistiges Eigentum der Fa. Hons Huber AG und damit urheberrechtlich geschützt. Zuwiderhandlungen verpflichten zu Schadenersatz. This is a copyrighted drawing which is the intellectual property of Hons Huber AG. Any contravening offender will be held liable for payment of damages.						
Technische Änderungen vorbehalten / Subject to modification						
Schlammwasser-Abzugvorrichtung (S14)			ISO 2768-mK			
sludge liquor discharge (S14)			D-92334 Berching / Tel.:08462/201-0			
Ver. Änderung	Datum	Name	Bezir./Rev.	Norm.	Blattzahl	Projektbez.:
Standard	Modified	Date	Region/Version	Standard	Sheet	Project Name:
Standard Item Code	Family	Family				
000000_190235			Projekt		Art.-Code Blatt	
- / 1			Project		Item Code Sheet	

HUBER
TECHNOLOGY