

➤➤ Sludge liquor withdrawal system S14

Completely made of stainless steel

Sludge liquor withdrawal is variable with the water level.
The scumboard for scum retention automatically adjusts itself to varying water levels.

With a DN 150 / DIN 2632 flange on the wall outside to provide for the attachment of a shutoff element on the basis of the following dimensions:

Wall thickness A = _____ mm

Distance S = _____ m

Maximum water level over outlet centre = _____ m

Upper tank edge over outlet centre H= _____ m

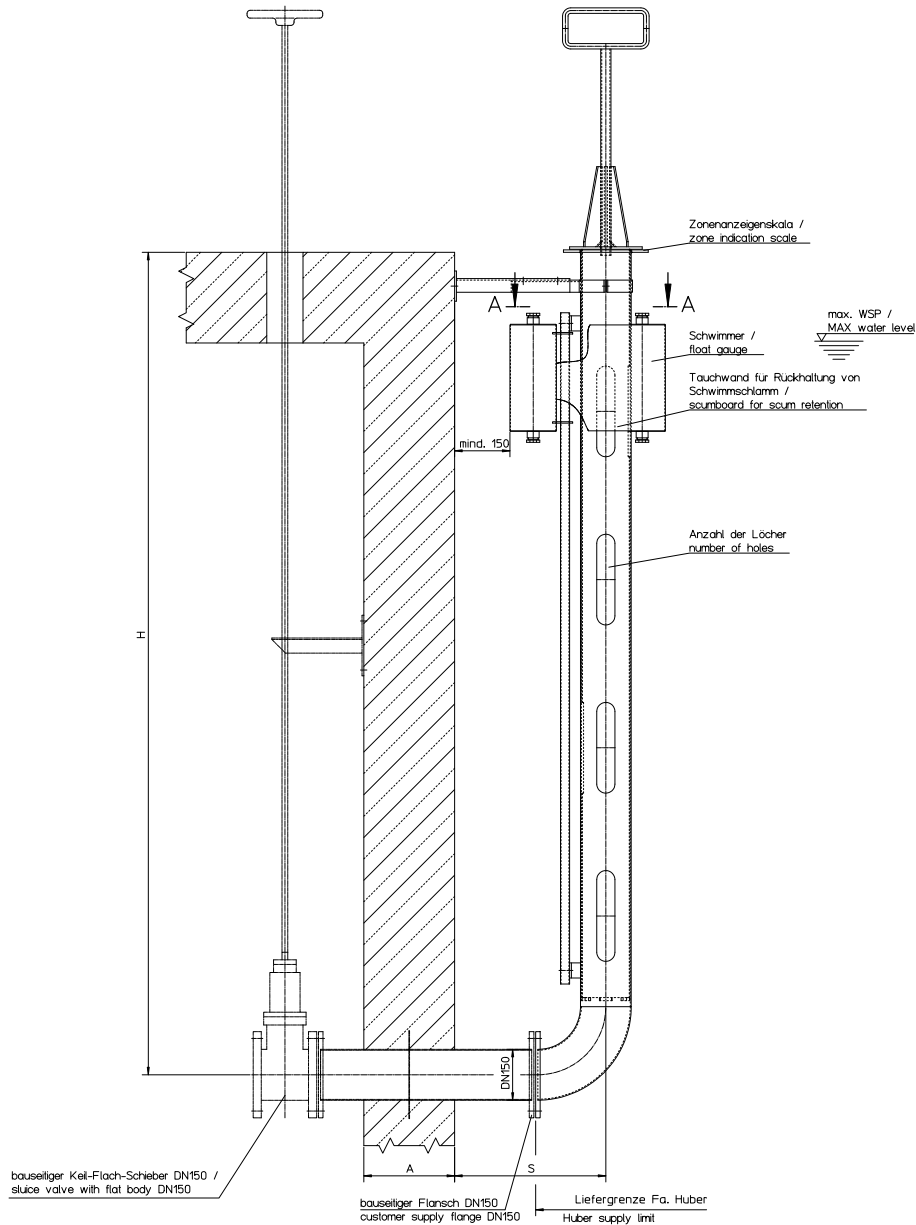

Schnitt/section: A-A

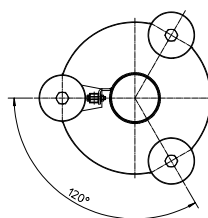

HUBER SE

Industriepark Erasbach A1 · D-92334 Berching
 Phone: + 49 - 84 62 - 201 - 0 · Fax: + 49 - 84 62 - 201 - 810
 info@huber.de · Internet: www.huber.de

Subject to technical modification
 Drawing No., 190.235 - 12.2008

Sludge liquor withdrawal system S14