



HUBER

Coanda Grit Classifier RoSF3

Grit separation and dewatering in one unit

- ▶ Utilisation of the Coanda effect ensures high grit removal efficiency
- ▶ Partly reduced organic content of the grit
- ▶ Maximum corrosion resistance and wear protection

More information,
downloads and
current news



The situation

Grit classifiers are widely used on sewage works for the removal of grit. Flow conditions ideal for maximum grit removal based on scientific definition have until now been unobtainable.

Previously designed plants based on past experience have often suffered from grit carry over due to insufficient retention time caused by undersizing of plant (consequence: deposits in digester, high wear rate of pumps) or conversely classified grit with a high organic content due to oversizing of plant. Consequence: high disposal costs, and wet grit due to insufficient dewatering.

The solution

The HUBER Coanda Grit Classifier RoSF3 was developed by HUBER in cooperation with the University of Munich, hydraulics department. Based on the Coanda-Effect, the flow into the tank can be defined exactly and simulated mathematically. When operating at optimum flow, the grit separation is up to 95 % (grain size 0.2 mm).

The difference in density between grit and other organic components can partly be taken into consideration to ensure reduced organic contamination and thus static dewatering of the classified grit. High efficiency has enabled the HUBER Coanda Grit Classifier RoSF3 to be significantly smaller than conventional classifiers.

Design and function

The grit / water mixture flows either by means of a pump or by gravity into the vortex chamber where a rotary motion is induced. An automatic air intake takes place through the centrally located drilling hole on the vortex chamber.

The heart of the HUBER Coanda Grit Classifier RoSF3 is the inserted Coanda Tulip. The organically laden water flowing in from the top adheres to the tulip wall and is diverted to the horizontal below water surface by the Coanda-Effect. Reduced radial and tangential flows assist the separation process and the difference in density between organic and mineral material is partly taken into consideration.

The classifier screw transports the clean grit up an inclined plane where it is dewatered under gravity before discharge into a skip. The mineral residue from a plant operating under optimum conditions is in excess of 90 % (e.g. a plant with appropriate pre-screening and grit collection facilities).

The benefits

- ▶ High levels of grit separation of 95 % of grain size 0.20 – 0.25 mm
- ▶ Screw supported on both ends for minimised wear
- ▶ High corrosion resistance
- ▶ Encapsulated, odour-free plant
- ▶ Option of frost-proof design

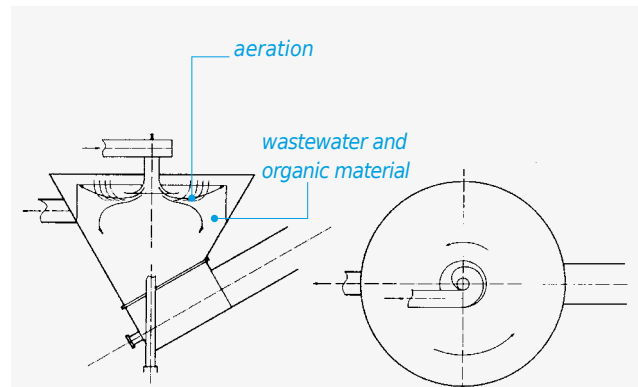

Schematic drawing of a HUBER Coanda Grit Classifier RoSF3.



A classifying screw transports the grit from the separation room into a skip.

HUBER SE

Industriepark Erasbach A1 | 92334 Berching
Phone: +49 8462 201-0 | info@huber.de
www.huber.de

HUBER Coanda Grit Classifier RoSF3

Subject to technical modification | 0,1 / 9 – 4.2022 – 9.2003